

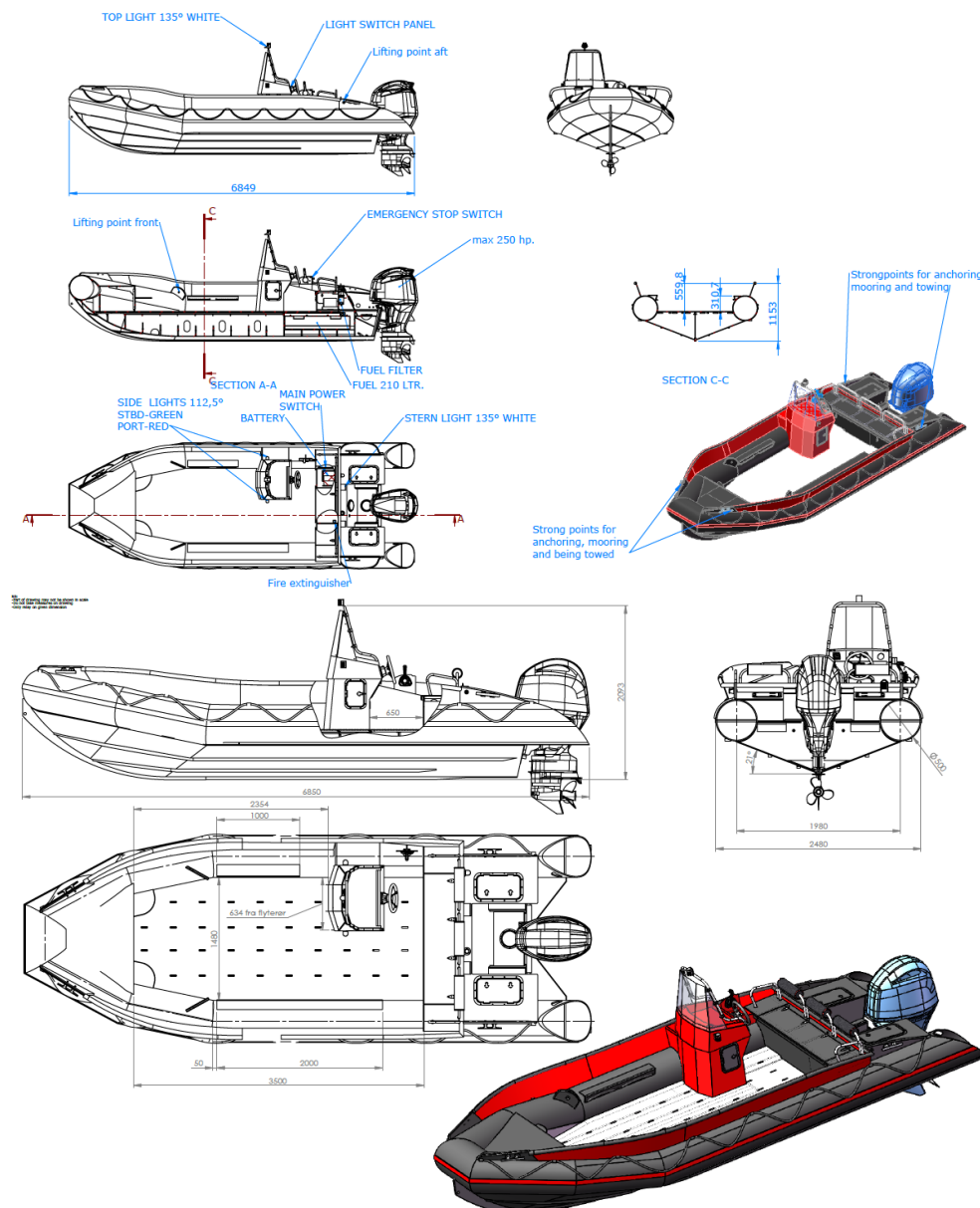

OWNERS MANUAL

Polarcirkel 685





Produsent: **Helgeland Plast AS, N-8607 Mo i Rana**
 Address: Båsmosjyen 4, 8607 MO I RANA
 Phone: +47 751 43 750
 e-post: info@akvagroup.com
 Web: www.akvagroup.com

Boatmodel: Polarcirkel 685
 Length: 6,85 m
 Width: 2,50 m
 Weight: approx. 1000 kg (Net.weight without engine)
 Max no of persons: 10
 Max engine: 186 kW
 Max engine weight: 355 kg
 Engine type: Outboard
 Steering: Steering wheel from console
 Weight empty boat (^mLC) ca 1355 kg. Emty boat with max engine
 Max. load (mL) 945 kg--equipment/baggage, persons and fuel
 Max depth.(Tmax): 60 cm
 Freebord (Fm): 50 cm at midship and loaded waterline
 Fuel tank: 1x210 liter
 Vanntank: -----
 Battery: 800cca
 Building material: Polyethylene. Floating tanks w/buoyancy integrated into hull.
 Design category: C – boats designed for wind forces up to and including force 6 and significant wave height up to 2 m
 Approval: The boat type is CE marked according to Regulations relating to production and sale m.v. of recreational vessels (2016).
 CIN nr.: Placed on top of stern SB side
 Safety equipment: Fire extinguisher (ABE), Manual bilge pump

1. ABOUT THE MANUAL	6
1.1 Introduction.....	6
1.2 BEFORE YOU GO:.....	6
1.2.1 CAUTION!	6
1.2.2 BEFORE START	7
1.2.3 WEATHER AND WIND.....	7
1.2.4 LOADING AND MAX NUMBER OF PEOPLE	7
1.2.5 Fuel.....	7
1.2.6 In case of problems	7
1.2.7 Engine and equipment	8
1.2.8 Securing loose equipment	8
1.2.9 Nautical charts	8
1.2.10 Onboard tasks	8
2 TECHNICAL DATA	8
2.1 CAPACITIES.....	8
2.2 BUILDERS PLATE	8
2.3 HULL IDENTIFICATION	9
2.4 CONSTRUCTION CATEGORIES.....	9
3 SAFETY CONDITIONS	11
3.1 WARNINGS AND MARKINGS	11
3.2 MANOEUVRE OF THE BOAT AND STABILITY.....	12
3.2.1 MAX ENGINE	12
3.3 EMERGENCY EXITS.....	12
3.4 HULL PENETRATIONS.....	12
3.5 BILGING-SYSTEM	12
3.6 FIRE PROTECTION AND EXTINGUISHING.....	12
3.7 MOORING AND TOWING	13
3.8 RESCUE EQUIPMENT AND FIRST AID	14
3.9 Protection against falling overboard and rescue equipment	14

3.9.1 Protection against falls overboard.....	14
3.9.2 Rescue after fall overboard.....	14
3.10 EMERGENCY	15
3.11 Visibility from driver position.....	15
Visibility from driver position may be affected by :	15
4. USE AND CONTROLS	16
4.1 OPERATION HANDLES / INSTRUMENTS	16
4.2 START / STOP IN GEAR.....	17
4.3 ENGINE START AND STOP.....	17
4.4 ENGINE, GEARS AND PROPELLER SYSTEM	17
4.5 FUEL-SYSTEM.....	17
4.6 COOLING SYSTEM.....	18
4.7 EXHAUST SYSTEMS	18
4.8 STEERING SYSTEM	18
4.9 ELECTRICAL SYSTEM	19
4.10 WATER AND SANITATION.....	19
4.11 GAS INSTALLATIONS	19
4.12 HEATING AND VENTILATION SYSTEM	19
5.0 MAINTENANCE AND STORAGE	20
5.1 LIFTING AND TRANSPORTATION.....	20
5.2 HULL	20
5.3 ENGINE AND GEARS	21
5.4 PROPELLERS, RUDDERS AND STEERING	21
5.5 OTHER INSTALLATIONS.....	22
5.6 STORAGE	22
6. WARRANTY AND SERVICE	22
6.1 DEALER AND WARRANTIES.....	22
6.2 DECLARATION OF CONFORMITY.....	23
7. Environmental considerations	23
8. ANNEX TO USER GUIDE	23
8.1 HEAVY OUTBOARD MOTOR.....	23

9.ONE-LINE DIAGRAM	24
9.1 Installation without engine and battery	24
9.2 Installation included engine	25
10. OWNERS NOTES	26
11. DATA SHEET AND MANUALS	27
12. Mounting of engine and control handle	28
ANTIFOULING	30

1. ABOUT THE MANUAL

1.1 Introduction

Congratulations with your new boat! Here at Helgeland Plast AS we have done everything possible to make sure you have a product which meets all safety and quality standards for this type of craft.

This Owner's Manual has been written so that use of the boat will bring you the maximum pleasure and safety. It contains important information about the boat, the systems onboard, the equipment available on and in the boat, and the handling and maintenance of the boat. Study the Owner's Manual carefully before starting operation.

If this is your first boat or if this is a boat type unfamiliar to you we strongly recommend that you make a thorough study of the boats handling and qualities before commencing serious use. Your local dealer or owners' association can refer to you to skilled instructors and coastal skipper's courses.

Look after this Owner's Manual and make sure it follows the boat if selling to a new owner.

This Owner's Manual complies with ISO Standard 10240.

Read this user manual! Before heading out to sea, check the following:

1.2 BEFORE YOU GO:

1.2.1 CAUTION!

Driving a boat is a responsibility not only for its own passengers but also for others who travel at sea. Pay attention to the waters for which the boat is built and always adjust the speed according to prevailing sea conditions.

In narrow waters and near smaller boats, consideration should therefore be given and avoid excessive speed. A boat at 20 knots moves about 10 meters per second.

The stop length increases markedly with increased speed and there are limited opportunities to influence it. Try to steer away from critical situations in good time.

1.2.2 BEFORE START

Before starting, it is important to ensure that safety equipment is approved on board, such as life jackets, mooring equipment, anchors and aids for lencing. This is the users responsibility.

Wear a life jacket or flotation garment.

1.2.3 WEATHER AND WIND

Assess the weather, the state of the sea, and visibility. Is the boat equipment and your skill-level adequate for the waters you are about to sail in? Respect the weather and wind and never go out in rough seas unless you and the crew are sure you can handle them, always adjust the boat's speed to the size of the waves and avoid getting waves directly in from the side.

Do not use a boat in poor visibility or after dark unless it has the stipulated navigation lights.

1.2.4 LOADING AND MAX NUMBER OF PEOPLE

Do not overload the boat, distribute the load evenly and make sure that everyone on board has flotation vests. The maximum permissible load and maximum number of persons are stated in the boat manufacturer's sign and master data on page 2 of this manual.

The stability of the boat is reduced if there is water from sea spray at the bottom. Avoid standing upright while driving as it can be slippery and the boat may have movements that are difficult to predict. Never stand more people upright in the boat at the same time.

Regardless of the number of persons on board, the weight of persons, cargo and motor must never exceed the maximum load stated on the builders plate.

All loads must be secured before starting. Loose loads can be shifted and adversely affect stability.

1.2.5 Fuel

Check that there is enough fuel, even reserve in case of bad weather. Spare cans for petrol must not be placed in living rooms connected to battery compartments as there is a risk of explosion.

1.2.6 In case of problems

Stop the engine before inspecting the propeller and with person(s) in the water by the boat!

1.2.7 Engine and equipment

Check the steering and the function of all electrical systems and perform the daily inspections listed in the Engine Manual. Check other seaworthiness issues, including possible fuel leaks, water leaks, and making sure safety equipment is on board, etc.

1.2.8 Securing loose equipment

Check that loose equipment is positioned so that they are kept in place even at sea.

1.2.9 Nautical charts

Take nautical charts with you for a sufficiently large area if you do not move in completely familiar waters.

1.2.10 Onboard tasks

Get along with the crew about who loosens which moorings, etc. Check that no mooring or other rope sits in the propeller/water jet when mooring or when unloading.

2 TECHNICAL DATA

2.1 CAPACITIES

Technical data and capacities are listed on page 2.

2.2 BUILDERS PLATE

The builders plate is usually located on the port side of the inner rear plate and provides information about: Boat manufacturer, Boat model, Construction category, Max. people (CL), Max. Total load: Persons + equipment, CE mark. Max engine weight

More detailed information is provided in this user manual.

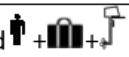
polarCirkel	PRODUSENT : HELGELAND PLAST AS			
	8607 Mo i Rana www.polarcirkel.no info@akvagroup.com tlf.+47 75 13 95 00 fax +47 75 13 95 01			
	Modell	685		Prod.nr.
	Design category	C		Year
	Max load 	1300	kg	Max engine weight
	Max engine single Max engine with twin installation	186,4 299	kW	Max.no. persons
<u>Max engine with manual control 15 kW.</u>		CE		

2.3 HULL IDENTIFICATION

The hull bears a permanent mark on the after transom, starboard side, with the hull identification which can be used to trace quality history.

NO-PCB12345A020

NO-	Code for Norway
PCB	Maker's ID letters
12345	building number
A	production month (here January)
0	Final digit, year of production (here 2020)
20	Two final digits, model year (here 2020)



2.4 CONSTRUCTION CATEGORIES

The EU/EEA's Leisure Boat Regulations became a mandatory part of the Norwegian legislation on 16 June 2015. Retrieved 10 June 2010. The CE mark in the boat is the manufacturer's sign and is the visible evidence together with the declaration of conformity that boat and equipment are meeting the requirements of these regulations.

Attached to this user manual follows a declaration of conformity that lists the standards used for the individual equipment parts of the boat.

The EU Leisure Boat Directive operates with 4 different construction categories:

Construction category	Wind force (Beaufort-scale)	Significant wave height (H 1/3, meter)
A	over 8	over 4
B	Until and included 8	Until and included 4
C	Until and included 6	Until and included 2
D	Until and included 4	Until and included 0,3

Polarcirkel model 685 is approved in Category "C".

3 SAFETY CONDITIONS

3.1 WARNINGS AND MARKINGS

As the owner of the vessel, it is your responsibility to acquire and the required safety equipment. For more information about mandatory safety equipment, please contact your local maritime authorities.

This manual defines unwanted situations that may occur as follows:

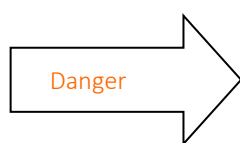

Indicates that an extreme danger is present and that this can lead to irreparable injury or death if the safety instructions are not followed. (DANGER)



The warnings in the book must be followed to avoid injury to persons. (WARNING)

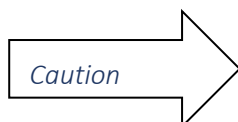

The precautions must be followed to avoid damage to the boat or equipment. (CAUTION)

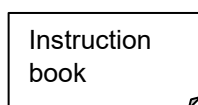

Read your own instruction book for the equipment.

MARKING *Operation of main power switch during operation*
Speed of ordinary operation

3.2 MANOEUVRE OF THE BOAT AND STABILITY

Always be sure to have good visibility from the steering position, Avoid quick movements of steering wheel without passengers being prepared. During operation, all passengers should sit and stick to the mounted retaining ropes to avoid accidents in sudden movements of the steering wheel. Keep in mind that waves and current conditions can affect the maneuvering properties.

Warning Keep in mind that twisting waves can affect stability and create dangerous situations.

3.2.1 MAX ENGINE

Warning Never equip the boat with a larger engine than recommended by the manufacturer, as it can adversely affect sea properties and result in dangerous situations.

3.3 EMERGENCY EXITS

Not applicable on this model

3.4 HULL PENETRATIONS

Not applicable on this model

3.5 BILGING-SYSTEM

The boat has a self-draining deck. There is a bilge pump to bilge the keel if there has become water under deck.

3.6 FIRE PROTECTION AND EXTINGUISHING

1 pcs fire extinguisher Maus Xtin kadium is placed in bench aft.

There is also a sign on the bench where it is placed.



3.7 MOORING AND TOWING

For towing you can use the mooring cleats on the front deck or alternatively those at the back.

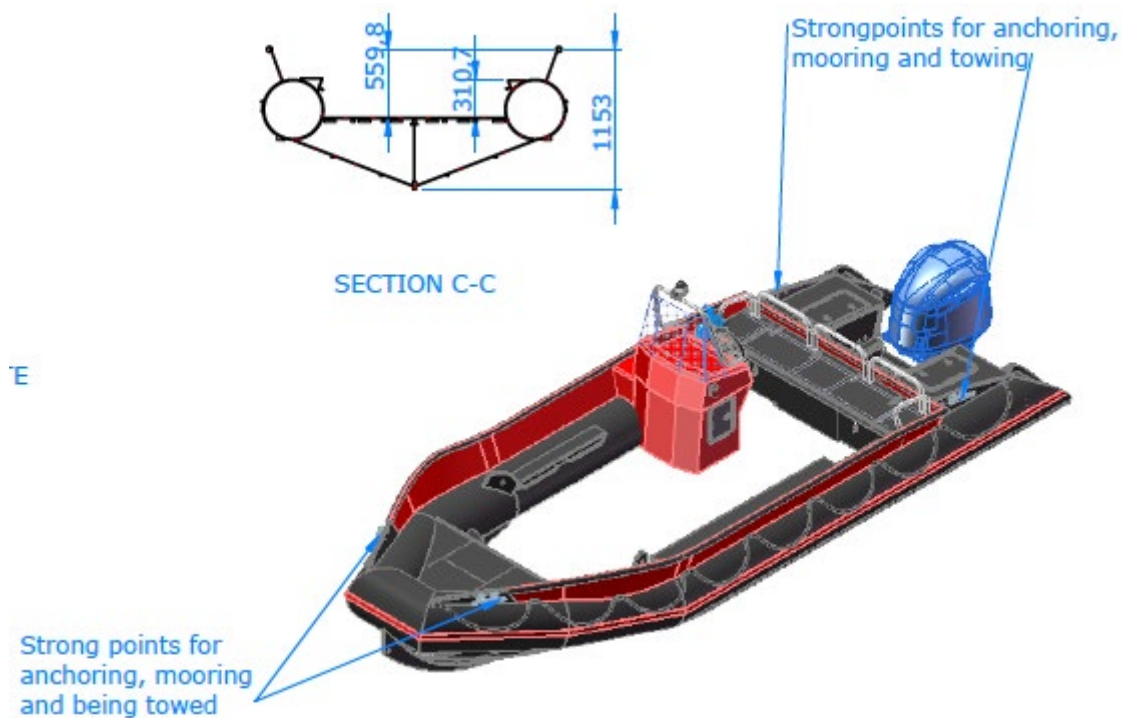

If mooring alongside a jetty we recommend tying the boat fore and aft. Do not tighten the lines excessively, as resulting sharp jolts in the lines can damage the mooring point on the boat or jetty, or both. We recommend minimum 16 mm mooring line. Breaking strength of at least 16,7 KN. Remember to hang fenders between the boat and jetty, minimum 3 fenders. Be sure to hang them correctly. Fender diameter should be minimum 9 inch.

If mooring between outriggers on a floating jetty we recommend using the starboard and port mooring irons both fore and aft. We recommend minimum 3 fenders on each side. Make sure mooring line is not too tight.

If using an anchor you can fasten the anchor line in the mooring iron fore or aft. Make sure the anchor is well seated on the bottom. The anchor can be stowed in the drag anchor chest forward or in the seat bench aft, and the line should be attached to the bottom or side of the drag anchor chest. All hatches and stowage compartments have drain holes.

3.8 RESCUE EQUIPMENT AND FIRST AID

The life raft is not included as standard equipment.

3.9 Protection against falling overboard and rescue equipment

3.9.1 Protection against falls overboard

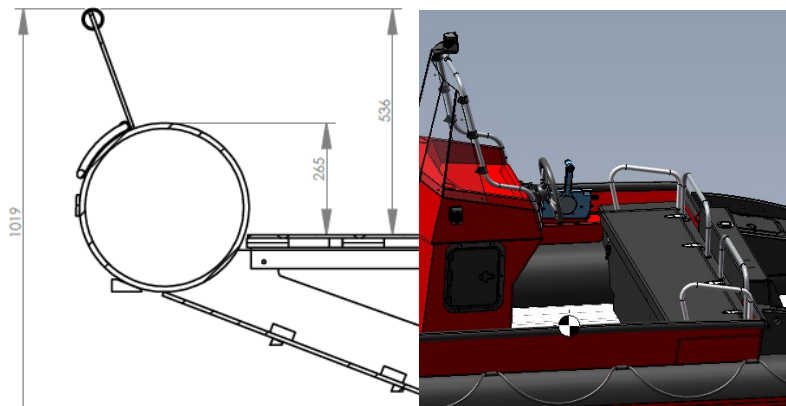

The boat has a height from bottom to top of bulwark of 536 mm. It's equipped with handles to hold in when sitting and/or standing and driving. Backrest on benches on pontons is 289 mm

3.9.2 Rescue after fall overboard

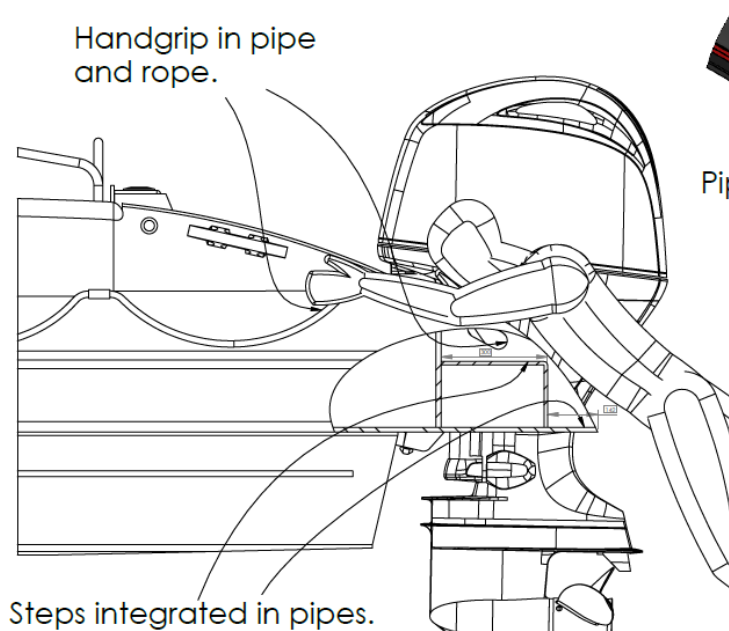

There are steps in the pontongen aft, with handles to pull up and then reach the rope on the outside of the boat for further help to get on board over the boat's stern and further into the deck.

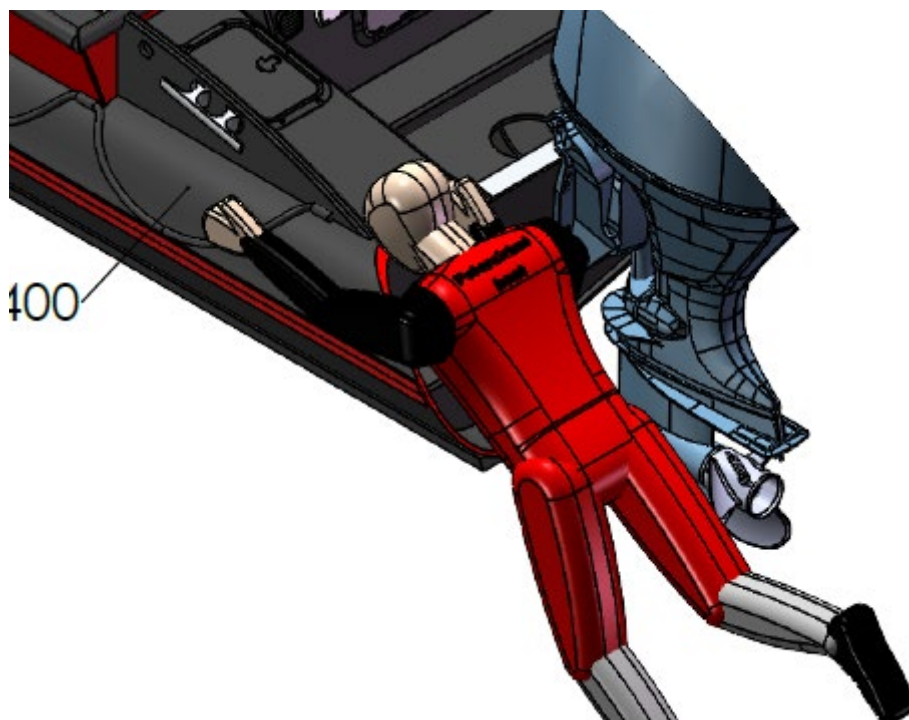

3.10 EMERGENCY

The boat operator is responsible for handling any emergency that occurs during the operation of the boat.

3.11 Visibility from driver position

Visibility from driver position is in accordance with NS-EN ISO 11591:2019. I.e. nothing prevents visibility forward further forward than a maximum of 5 times the boat length in loaded condition from the standing driver position

Caution

Visibility from driver position may be affected by :

1. Cargo in the boat
2. Tuning angle of the engine
3. Strong acceleration

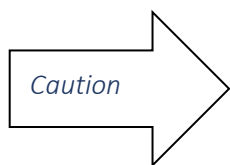

4. Speed
5. Transition between displacement speed and leveling speed
6. Conditions at sea, wave heights e.g.
7. Weather conditions such as rain and fog
1. Glare of e.g. lanterns
8. Persons or removable cargo

4. USE AND CONTROLS

This chapter offers information, recommendations and hints for the practical use of the boat and equipment. The descriptions serve two main purposes: to promote maximum safety, and promote correct use for a long and trouble-free life. This will mean a good second-hand price for the boat. Ensuring the servicability of all components at all times means not simply greater satisfaction for users, but also has a major impact on safety.

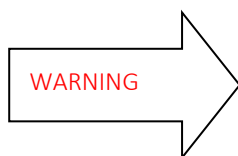

WARNING: Before departure it is important to ensure that the boat is carrying certified safety equipment, including lifejackets, fire-fighting appliance, anchor, etc. During operation passengers must not stand on the foredeck or sit on the railing edge. Avoid standing up in the boat. Wear a lifejacket when stepping on the flotation tubes or when outside the boat.

4.1 OPERATION HANDLES / INSTRUMENTS

Read the instruction manual carefully and check the function on:

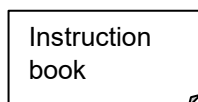

1. Handles (remember to operate the maneuver handle with care, rapid movements may damage wire)
2. instruments, switches and fuses

4.2 START / STOP IN GEAR

Read the engine supplier's manual carefully to ensure that the engine is not possible to start in gear.

4.3 ENGINE START AND STOP

Before startup check the following:

Instruction
book

- That the cooling water intake valve is opened (if the inboard motor)
- That all couplings and hoses are intact.
- That battery is connected by the main switch
- That other start up procedures from the engine's instruction-book have been followed.
- Always keep the engine cover closed when the engine is started.
- Never enter the water with the engine running.
- Stop the engine before inspection of the propeller..
- Do not use an open fire while refueling.
- Clean boat immediately after petrol/oil spill.
- The deck becomes slippery in case of gasoline/ oil spill.

Warning

4.4 ENGINE, GEARS AND PROPELLER SYSTEM

Inspection of the engine and gear shall take place according to the engine inspection book supplied by boat. In particular, check that the zinc anodes are intact.

4.5 FUEL-SYSTEM

Outboard engine:

Access to petrol tank. Petrol filter inside the round hatch



Generally:

When filling fuel pay special attention to the following points:

1. Check that the boat is securely moored.
2. Check any leaks in the couplings/tank/filling fittings/aeration/fuel lines/filters etc.
3. Stop the engine and any electric fans.
4. As accurately as possible, check how many litres of fuel to fill.
5. Be careful not to enter the hull/keel of the boat.
6. After refilling, ensure that the filling cap is properly screwed and closed.
7. Dry up any fuel spillage.
8. Check that there is no evidence of fuel leakage in engine compartments/at tanks or below deck.

4.6 COOLING SYSTEM

See owners-manual for engine

4.7 EXHAUST SYSTEMS

Not applicable for outboard engine

4.8 STEERING SYSTEM

The hydraulic steering system consists of a steering pump and a steering cylinder.

You need to fill up the steering pump with oil from time to time. The oil level must always be above the pump mechanism (look through fill plug hole). The fill plug in the pump housing is opened and oil is added until the level is above the pump mechanism. After topping up you may also need to bleed the system.

Turn the wheel several turns to one side, while simultaneously loosening the cylinder bleed valve. Repeat from one side to the other until there are no visible air bubbles in the oil. Close the bleed valve before changing the direction of rotation.

After bleeding the steering should feel "firm", with no springiness or audible sounds. Repeat bleeding process as necessary. Use only Sea Star Hydraulic Steering Fluid.

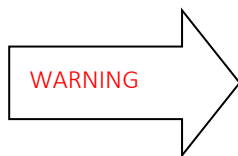

Any hydraulic system will quickly be degraded if contaminants are allowed to enter the system, so be particularly careful not to admit dirt or dust e.g, and be especially critical of oil quality. Wipe up any oil spill immediately.

4.9 ELECTRICAL SYSTEM

The boats are equipped with 12V facilities as standard. One-line diagram in this manual

4.10 WATER AND SANITATION

Not applicable on the model

4.11 GAS INSTALLATIONS

Not applicable on this model

4.12 HEATING AND VENTILATION SYSTEM

Not applicable on this model

5.0 MAINTENANCE AND STORAGE

5.1 LIFTING AND TRANSPORTATION

Lifting the boat:

The boat can be lifted in straps under the boat hull or by using the lift points in the boat. The outboard model comes standard with 2 lifting points in the stern and 1 in the bow (eye in the keel).

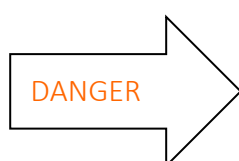

Do not stand under the boat when lifting!

Transport of the boat:

When the boat is transported on a vehicle, the weight of the boat should rest on supports under the keel of the boat, adjusting the side supports to avoid displacement. Do not forget to attach any loose load to the boat. Nb! When transporting on a boat trailer, support wheels should come as close as possible to the transverse spun in the hull. Spun placement seems relatively good under the boat.

5.2 HULL

A polyethylene boat has a long lifetime and needs minimal maintenance to be safe during use. However, by following a few simple maintenance points, the boat will stay fresh for longer, have higher value and increase enjoyment when used. The boat is built up of polyethylene pipes and plates. This material does not need special treatment to be resistant and can withstand major mechanical stresses. However, it is recommended that the boat be carried out with caution when there is a risk of contact with ground or structures in the sea.

Maintainance	Remark
Bottom lubrication, see separate form	If necessary
Wash the hull with fresh water added to the water detergent. Strong solar irradiation mattifs down the plastic surface.	Before launching, in winter circulation and if needed during the season.
Metal parts oa. can be protected with advantage. by inserting it with Vaseline grease	At winter storage

Check any presence of water in inner keel by checking with bilge pump on outboard models.	1 x pr week
Check the status on drain hose grow, function	1 x pr month

Please note that the deck plates will expand at temperature differences. This will give small "dents" on the deck. This is completely normal and is without the risk of damage to the deck or other construction . Be careful not to apply high pressure washers to emblems – they can loosen!

5.3 ENGINE AND GEARS

The boat owner is responsible for carrying out ongoing maintenance/service on the engine after intervals described in the accompanying engine user manual.

Maintainance	Remark
Read the motor supplier's manual carefully and follow the instructions.	Before launching
Check gas/gear cabling	Before launching
Check engine oil level regularly	
Periodic checks and replacements	See supplier's manuals

5.4 PROPELLERS, RUDDERS AND STEERING

Maintainance	Remark
Propeller – blade, nut and splint are checked	Before each launch
Check couplings, hoses, fasteners and bearings.	Regularly
Check oil level in steering system	Regularly
Check control functions, fasteners	Before launching
Lubricate couplings and joints.	Before launching and if needed when boat is on water

5.5 OTHER INSTALLATIONS

Not applicable on this model

5.6 STORAGE

The boat is best stored covered or in house and it should be well supported and stand straight. Please note that water and snow left inside may damage the boat.

If the boat is equipped with an engine then check the steering functions before putting the boat on the water and lubricate the couplings and joints. For replacements, periodic inspections and engine maintenance, see the motor supplier's instruction manual.

6. WARRANTY AND SERVICE

6.1 DEALER AND WARRANTIES

Helgeland Plast AS with associated dealers can be consulted on any issues that may arise. Please contact the responsible seller in the guarantee period regarding the boat.

For equipment that is generally included in the boat such as:

- Engine and drive
- Instruments
- Compass
- Other accessories/merchandise

Contact Helgeland Plast AS for information about your local dealer.

Warranty notes are delivered with the boat..

Helgeland Plast AS provides a 1-year warranty against manufacturing defects on plastic works.

Insurance.

Boat insurance replaces damage that occurs at sea or during transport and docking. Insurance also has an indirect impact on the safety of the sea: in the event of a serious accident you can concentrate

on saving human lives. More information on different insurance options can be obtained from insurers.

6.2 DECLARATION OF CONFORMITY

Attached to this user manual is the boat's declaration of conformity. It is the boat builder's declaration that the boat is built according to the rules and standards that apply to this type of boat.

7. Environmental considerations

- Fuels and oil spills
- Garbage/ chemicals/ paints
- Noise
- Waves
- Exhaust

8. ANNEX TO USER GUIDE

8.1 HEAVY OUTBOARD MOTOR

POLARCIRKEL Standard, for outboard motors are approved with the following max power:

Polarcirkel 685 has a max engine 250 HP for single installation.

For twin installation, 2 x 130 HP is the max engine.

When using heavy 4-stroke engines, the relatively high weight of the engine will cause the exhaust outlet to come very low above the water mirror. Therefore, please note the following:

The engine should never be abandoned tilted down but should always be tilted up when the engine is stopped. This is important to prevent salty water from entering the engine and the exhaust outlet. Helgeland Plast AS accepts no responsibility for damage to the engine as a result of the intrusion of salty water.

9.ONE-LINE DIAGRAM

9.1 Installation without engine and battery

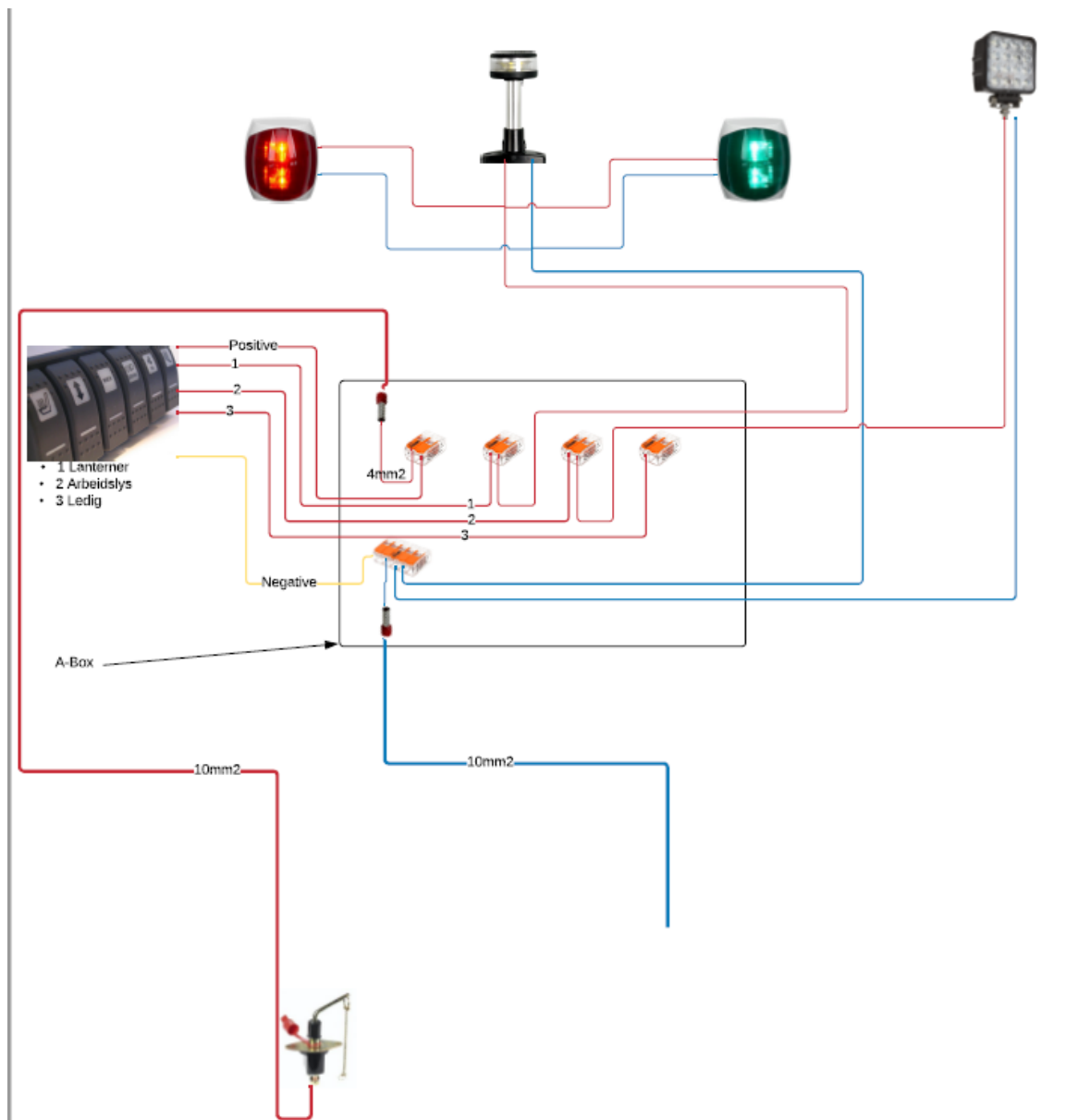

10. OWNERS NOTES

11. DATA SHEET AND MANUALS

The following is attached to this user manual:

- Warranty card engine (if delivered from Helgeland Plast AS)
- Owners manual for engine
- Declaration of conformity

12. Mounting of engine and control handle

Cables from controls are pulled into the back bench and into the pre-cut holes further out to the back of the engine well. Use engine supplier rigging hoses.



The cables go down the backbench





Guide hoses are mounted as in the picture

Open the screw cap in the middle of the well to install the lowest screws on the engine bracket

Gas / gear cables are 9 feet long

Note!! When installing the engine of 250 HP or more, a reinforcement plate must be installed from alu. or stainless steel, 8 mm thickness. Adapts to the motor bracket, see picture.



Disposal of the boat :

As the boat is manufactured in polyethylene, it is fully recyclable and thus very environmentally friendly. Only minor deposits of wood and aluminum inside the boat must be removed before the plastic can be recycled. The cabin of fiberglass and windows and other glass and metal that are mounted in the different models are supplied for suitable reception for such things.

NICE TO KNOW...*Stainless/ Acidproof:*

Stainless steel (A-2, 304, 312) does not rust like normal steel, but in a salty environment may form an oxide coat on the surface. Acidproof steel (A4, 316) containing molybdenum will withstand salty conditions without deterioration of the surface finish.

Navigation light requirements:

Motor boats of less than 12m shall carry a top light forward visible minimum 2 nautical miles distant, red and green side lights, and a white aft light visible minimum 1 nautical mile distant.

The white top light and aft light may be combined in a fully circular white light visible minimum 2 nautical miles distant.

The top light or fully circular white light must be carried minimum 1 meters above the side lights

ANTIFOULING

As the polyethylene is an oil based material and therefore may sweat a bit in the surface the first year. We recommend to wait to the second year before antifouling the bottom plates.

We recommend Hempel antifouling

<https://www.hempelyacht.no/nb-NO/product-list/products-category?type=antifoulings>